

Coastal Habitat and Sea Duck Conservation Plan

**for the
Town of Mary's Harbour**



The Town of Mary's Harbour with Assistance from the Staff of the
Eastern Habitat Joint Venture
2010

Coastal Habitat and Sea Duck Conservation Plan for the Town of Mary's Harbour

Date: January 19, 2010

**Prepared by the Town of Mary's Harbour with assistance from staff of the
Eastern Habitat Joint Venture**

Contact Information:

**Town of Mary's Harbour
P.O. Box 134
Mary's Harbour, NL
A0K 3P0
Tel: (709) 921-6281
Fax: (709) 921-6255**

**NL Eastern Habitat Joint Venture
Department of Environment and Conservation - Wildlife Division
117 Riverside Drive
P.O. Box 2007
Corner Brook, NL
A2H 7S1
Tel: (709) 637-2006
Fax: (709) 637-2032**

Preface

In Newfoundland and Labrador some of the seaducks and coastal habitat that are in greatest danger of being negatively impacted are those influenced by residential, commercial and industrial activities within the vicinity of municipalities. In this province, the primary focus of the Eastern Habitat Joint Venture is to conserve valuable waterfowl habitat (wetlands, coastal islands and associated uplands) through Stewardship Agreements. The Town of Mary's Harbour was identified as having just such valuable coastal habitat and seaducks, particularly in nearby St. Peter's Bay.

The Town of Mary's Harbour signed an agreement in 2009 pledging their commitment to conservation and protection of seaducks and coastal habitat within a specified Stewardship Zone. In accordance with this agreement, Mary's Harbour manages these areas with technical advice provided by the provincial Wildlife Division, in part via this Conservation Plan. With the signing of this plan, the agreement parties officially accept this Conservation Plan and agree to use it as a guide to govern activities within the designated Stewardship Zone.

The following signatories agree to work towards the implementation of the following "Coastal Habitat and Sea Duck Conservation Plan" for the Town of Mary's Harbour:



Mayor
August 27/2010

Date



Witness
August 27, 10

Date



Director, Wildlife Division,
Department Environment and Conservation
9-16-10

Date

Table of Contents

Section 1: Plan Overview.....	1
Plan Purpose	
Plan Goals	
Plan Objectives	
Section 2: Coastal Habitat & Sea Duck Conservation in Newfoundland & Labrador.....	2
Coastal Habitat and Threats	
Eastern Habitat Joint Venture	
NL EHJV Coastal Habitat Stewardship Program	
The Stewardship Agreement Process	
Roles of Stewardship Agreement Signatories	
Section 3: Coastal Habitat and Sea Ducks Associated with the Town of Mary's Harbour.....	7
The Town of Mary's Harbour	
Why St. Peter's Bay?	
The Common Eider	
The Harlequin Duck (Eastern Population)	
Harlequin Duck in Mary's Harbour	
Description of the Stewardship Zone	
Existing Land Use and Its Potential Impact on Coastal Habitat and Sea Duck/Wildlife Populations	
Section 4: General Policies for Coastal Habitat and Sea Duck Conservation.....	13
The Town's Commitment to Stewardship	
Benefits for Residents	
Habitat Management of the Stewardship Zones	
"Wise Use" of the Stewardship Zone	
Management by Committee	
Section 5: Coastal Habitat and Sea Duck Conservation and Education Strategies.....	16
Artificial Nest Shelters	
Sea Duck/Seabird Monitoring Program	
Hunting	
Oil Spills	
Recreational Use Development	
Conservation Corps Green Teams	
Artificial Nesting and Loafing Structures	
Educational Programs	
Habitat Enhancement	
Litter Removal	

List of Figures

Figure 1: Common Eider.....	8
Figure 2: Male Harlequin Duck.....	10
Figure 3: Eider Nest Shelter.....	16
Figure 4: Osprey Nesting Platform, Stephenville Crossing.....	20
Figure 5: A Newfoundland Beach Cleanup, Vanaqua Shoreline Cleanup.....	23

Appendices

Appendix 1: Coastal Stewardship Agreement.....	25
Appendix 2: Map of the St. Peter’s Bay Stewardship Zone.....	29
Appendix 3: Detailed Map of the St. Peter’s Bay Stewardship Zone.....	30
Appendix 4: Some Avian Species found in St. Peter’s Bay.....	31
Appendix 5: Instruction/Materials for Construction of Common Eider Nest Shelters.....	32
Appendix 6: Community-Based Waterfowl Monitoring.....	33
Appendix 7: Appropriate Wording Required for Potential “No-shooting” Signs.....	38
Appendix 8: Potential Artificial Osprey Nesting Platform.....	39
Appendix 9: Potential Constructed and Floating Islands.....	41
Appendix 10: Bird-watching (Viewing) Towers.....	45
Appendix 11: Construction of Bird Blinds.....	46
Appendix 12: Observation Platforms.....	48

Section 1: Plan Overview

Plan Purpose: The Town will use this Conservation Plan as a guide to govern activities which impact coastal habitat and sea ducks in order to minimize negative impacts within the areas designated for conservation (Stewardship Zone).

Plan Goals:

- (1) To conserve and promote wise use of coastal habitat and sea duck populations located within the designated Stewardship Zone.
- (2) To maintain and/or increase wildlife use of those areas, particularly by sea ducks and other avian species.
- (3) To increase public awareness of the importance of coastal habitats for conserving sea ducks and other wildlife.

Plan Objectives:

- (1) To present a general assessment of the coastal habitat and sea ducks or wildlife species designated for protection.
- (2) To recommend protection, conservation and enhancement strategies for the Stewardship Zone.
- (3) To describe potential initiatives for education and awareness among the public in order to increase support and cooperation of the Town's citizens.

Section 2: Coastal Habitat and Sea Duck Conservation in Newfoundland and Labrador

Coastal Habitat and Threats

Human development has resulted in the destruction of many types of habitat all over the world. Coastal habitats, including offshore islands, saltwater marshes/ponds, beaches, and surrounding dune systems are some of the areas most critically affected by this development and are, in fact, some of the most sensitive ecosystems on the planet. These areas play a major role in the status of continental ecosystem health, as well as regional and local ecosystem health. However, human activities have already altered and damaged a significant proportion of the world's and Newfoundland and Labrador's coastal landscape.

Coastlines provide excellent habitat for all kinds of both common and rare animals and plants. Significant along these is providing breeding, moulting, staging and wintering habitat for waterfowl, sea ducks and seabirds. Newfoundland and Labrador has many harbours, bays and offshore islands which support a significant population of breeding waterfowl, seabirds and seaducks. In fact, colonial nesting birds such as Common eider, Puffin, Razorbill, and Leaches Storm-petrel nest exclusively on offshore islands. Additionally, the Harlequin duck, a species at risk, winters and feeds along exposed rocky headlands and reefs of coastal islands.

Newfoundlander's and Labradorian's have a strong cultural connection to the ocean and its surrounding coastlines. Much of our economic history is tied to coastal dependant industries, such as fishing, oil and gas development, aquaculture production and pulp and paper mills. These industries often play a large role in the economies of small coastal communities. Coastal areas have long provided residents with opportunities to pursue traditional activities such as hunting, fishing, boating, hiking and berry-picking, and nontraditional activities such as birdwatching. Today, the eco-tourism industry is starting to introduce visitors to these special places. None of these activities are bad by themselves but they have the potential to have a negative impact on local sea duck and seabird populations if not carried out with care.

Coasts are an interface between the land and the sea. River mouths, estuaries, wetlands, and ponds are where upland waters accumulate before draining to the sea. Coastal lands are also impacted by waves and subterranean salt water intrusion. During intense storms or heavy precipitation events, coastal areas are often flooded by fresh or coastal waters. Coastal development can lead to the loss or alteration of wetlands and other important flood control systems. Development can change infiltration rates and drainage patterns throughout the watershed thereby increasing the risk of flooding in coastal areas. It can negatively impact water quality putting at risk a community's drinking water supply, shellfish harvesting areas, and recreational uses. Poor water quality also disrupts the marine and coastal ecosystems and puts both animal and plant life at risk. Newfoundland

and Labrador's coastal waters are contaminated by a variety of onshore and offshore sources of pollution. Land-based pollution sources include sewage waste dumping, leaking septic systems, agricultural and urban runoff, industrial emissions including sulphur dioxide and chlorofluorocarbons (CFCs), spilling or seepage of metals, pesticides and petroleum. Water based pollution sources include oil spills and bilge dumping. Increased coastal development has also reduced the opportunity for residents and visitors to gain access to the coast for traditional livelihood activities such as fishing, hunting, and boat launching. Recreational activities such as swimming, beach walks, and pleasure boating are also affected. Newfoundlanders and Labradorians want to maintain their traditional connection to the coast.

Eastern Habitat Joint Venture

The number and diversity of North America's wildlife species has been declining over the latter half of the twentieth century. At least a portion of this decline can be directly attributed to the loss of natural habitats to urban, industrial and agricultural expansion. In recognition of this Canada, the United States and Mexico have signed the North American Waterfowl Management Plan (NAWMP), thereby committing themselves to a long-term program of partnership projects aimed at assuring the survival and increase of waterfowl populations and protecting the habitat on which their survival depends. A total of 21 joint ventures, ranging from species to regional-specificity, have been established to achieve and implement the objectives of the NAWMP. The province of Newfoundland and Labrador, through the provincial Wildlife Division, became a partner of the Eastern Habitat Joint Venture (EHJV) in 1989.

The primary premise behind the EHJV is to conserve, enhance and restore habitat for for waterfowl and wildlife in the six eastern Canadian provinces including Ontario, Quebec, New Brunswick, Nova Scotia, Prince Edward Island and Newfoundland and Labrador. Each provincial program is somewhat unique, coordinated by a separate program manager, and involves the cooperation of international partners, including government agencies and non-government groups, each working to forward specific goals and objectives of the NAWMP. In Newfoundland and Labrador, the program is administered through the provincial Wildlife Division of the Department of Environment and Conservation. Its local contributors, other than the province, include Ducks Unlimited Canada, Canadian Wildlife Service, Nature Conservancy of Canada and Wildlife Habitat Canada. While each province may function independently, the Eastern Habitat Joint Venture works towards attaining common goals of influencing larger goals of habitat quality and quantity in Eastern Canada through conservation, enhancement and/or restoration initiatives.

NL EHJV Coastal Habitat Stewardship Program

Coastal habitats have historically been affected by heavy development pressure. In Newfoundland and Labrador development pressure occurs regularly and most often within and surrounding municipal boundaries. The NL EHJV Coastal Habitat Stewardship Program's principle goal is to help make municipalities, corporations, developers, landowners and other habitat stakeholders more aware of the value of coastal habitat and wildlife and to empower them to undertake their own actions to conserve this habitat. Its central premise is that each person has the responsibility and opportunity to contribute towards the sustainability of our sea duck and seabird populations so that we may continue to enjoy the privileges associated with both our consumptive and non-consumptive use of our outdoor resource. This individual stewardship also helps to lead to more informed development decision-making and works towards minimizing negative impacts on coastal habitat and local ecosystems as a whole.

The Coastal Habitat Stewardship Program focuses primarily on sea ducks, specifically the Common Eider. Sea ducks represent one-third of all North American waterfowl species but originally received no special consideration under the original North American Waterfowl Management Plan because their populations were thought to be stable. The biology of sea ducks differs from most other ducks in that their life spans are longer, most species breed later, lay fewer eggs and, on average produce fewer ducklings per year. Analysis of existing survey and harvest data along with new surveys conducted during the 1990's have indicated population declines in 10 of the 15 species of North American sea ducks. This alarming fact precipitated the formation of the Sea Duck Joint Venture (SDJV) in 1998 whose mission is to promote conservation of North American sea ducks by providing greater knowledge and understanding to effectively manage sea ducks. The Coastal Habitat Stewardship Program was developed under the auspices of the EHJV to complement the activities of the SDJV. The program focuses largely upon signing coastal habitat stewardship agreements with municipalities, corporations and individual landowners who are located in close proximity to significant coastal habitat and who have a historical connection to the ocean and the coastline. A coastal habitat stewardship agreement represents a formal public commitment by a community, corporation, individual and the province, to act together to conserve sea ducks and coastal habitat. By signing a coastal habitat stewardship agreement, communities, corporations and individuals become an important link in a continental chain of conservation areas. To date, coastal habitat stewardship agreements have been signed by St Anthony (Hare Bay), Mary's Harbour, St Lewis and Red Bay (St Peter's Bay), with an agreement in principle reached with Cartwright (Table Bay).

The Stewardship Agreement Process

Initial contacts are generally sought by both EHJV staff and by local community leaders who wish to take action to conserve sea ducks and coastal habitat. A determination is made between the parties of whether there exists mutual interest in pursuing a stewardship agreement (see Appendix 1). At the same time, surveys of the coastal habitat and sea duck/wildlife populations within a certain area of interest are carried out by EHJV staff to confirm a significant relationship exists between coastal habitat and local sea duck/wildlife use in the area.

Following these positive assessments, more intensive field investigations will be carried out to determine and agree on formal boundaries for a Stewardship Zone. A designated “Stewardship Zone” functions as the area of interest that reflects existing coastal habitat and sea duck/wildlife populations of significance, either within a Town’s municipal planning boundary, or within some geographic proximity. (Appendix 2)(Appendix 3)

When sufficient information has been gathered, a preliminary proposal is presented to a community, individual or corporation for review, with suggested boundaries for the Stewardship Zone clearly indicated. After the Stewardship Zone has been agreed to, a formal Coastal Habitat Stewardship Agreement will be signed between the presiding body (town, corporation, landowner) and the province. Under this agreement, the town, corporation or landowner maintains ultimate control over all areas within its jurisdiction, but are asked to abide by the details of the agreement (see Appendix 1).

After the signing of a formal agreement, the Eastern Habitat Joint Venture staff will assist the community, corporation or individual in preparing a Coastal Habitat Conservation Plan specific to the community, individual or corporation. This plan will serve to offer coastal habitat-related best management practices and will provide recommendations and advice for conserving, enhancing and/or managing the coastal habitat and sea duck/wildlife populations within the Stewardship Zone. Coastal Habitat Stewardship Agreements are signed with the hope that when municipal, corporate, or individual land use decisions are made, the value of coastal habitat and sea ducks/wildlife will not be forgotten and that future land-use activities will not have a negative impact upon these values.

Roles of Stewardship Agreement Signatories

“The Province”- The Minister of Environment and Conservation is generally the designated signatory on behalf of the province. The Wildlife Division administers the Eastern Habitat Joint Venture in Newfoundland and Labrador. As such, staff of the Wildlife Division, are assigned, to implement on a provincial basis, the EHJV partnership program.

As a result of signing a coastal habitat stewardship agreement staff of the EHJV are expected to:

- Assist the Town in preparing a coastal habitat conservation plan.
- Review proposed developments within the stewardship zone(s) that have the potential to impact coastal habitat or sea duck/wildlife populations.
- Assist in carrying out community education initiatives to help raise awareness of coastal habitat related issues, and
- Support community conservation groups in implementing the stewardship agreement and conservation plan.

As a result of signing a coastal habitat stewardship agreement the Town or Municipality and its designated Mayor/Council are expected to:

- Ensure wise use, in consultation with staff of the EHJV, within the designated stewardship zone(s), namely to contact staff of the EHJV when activities are formally proposed that may impact that habitat or sea duck/wildlife populations.
- With the assistance of the EHJV to educate residents, industry and development planners about the stewardship program and their responsibilities.
- Implement over time the conservation plan recommendations in the community at large and within the Stewardship Zone.

Section 3: Coastal Habitat and Sea Ducks Associated with the Town of Mary's Harbour

The Town of Mary's Harbour

Mary's Harbour is located at the mouth of St. Lewis Inlet and is approximately 168km north of Blanc-Sablon, Quebec and approximately 25km north of St. Peter's Bay. In the 1780's Mary's Harbour was a site where fisher people harvested Atlantic Salmon on the St. Mary's River. It was not until the 1930's, after a fire in the nearby village of Battle Harbour, that the town became a permanent settlement. Mary's Harbour, now with a population of 417 (Statistics Canada 2006), has always depended on the cod fishery for their main source of income. Since the moratorium, however, the town had to find other sources of income to rely on. With the start of the Labrador Shrimp Company many residents focused on the Crab Fishery as an alternate source of income.

Residents of Mary's Harbour now depend on other services, facilities, and businesses in Mary's Harbour including a clinic, hotel and bed and breakfast lodgings, a post office, credit union, a personal home care facility, an all grade school, and recreation and family resource centers. Retail businesses they depend on in the area include grocery stores, a liquor store and gas stations, craft shops, beauty salons, and others. There are also a number of government services in the area as well; they include the Department of Human Resources Labour and Employment, Fisheries and Aquaculture, Transportation and Works and the Department of Child Youth and Family Services, the RCMP and the NL Hydro. Associations and committees for the historic village of Battle Harbour exist, as well as the Mary's Harbour Fishermen's committee.

Why St. Peter's Bay?

St. Peter's Bay is located approximately 25km south of Mary's Harbour and is approximately 5km wide with several small islands located in its middle. The waterfowl in St. Peter's Bay, particular the common eider (*Somateria mollissima*), utilize the rocky coasts, shoals, and islands at various times throughout the year. The vegetation on the islands is limited to sedges, grasses, stunted trees and crowberry barrens which they utilize for breeding, nesting, molting, staging and over wintering. The Canadian Wildlife Service considers the bay to be the only primary moulting area for eiders along the southern Labrador coast south of Table Bay, with estimates of up to 3000 molting eiders congregating there during the months of July and August. Other waterfowl which frequent St. Peter's Bay include black duck, Canada goose, common merganser, various species of scoter, and the harlequin duck (see Appendix 4).

In 1942 the Newfoundland Rangers estimated a breeding population of approximately 500 pairs of common eider in the St. Peter's Bay archipelago, however by 1969 only 51 pairs were counted. The Canadian Wildlife Service (CWS), at the request of the newly

formed provincial government, established a federal Migratory Bird Sanctuary in St. Peter's Bay in 1949. By 1980 no appreciable increases in populations were recorded and sanctuary designation was revoked. Recent counts and aerial survey data recorded during the 1980's and 1990's suggest that concentrations of sea ducks in the area may be increasing and that their status merits further investigation. This project will help residents to understand the significance of St. Peter's Bay for all life stages for migratory sea ducks.

St. Peter's Bay is visited regularly by people from several communities on the coast for a variety of consumptive and non-consumptive activities such as berry-picking, fishing, small game and waterfowl hunting, boating, sightseeing, snowmobiling and so on. There is less commercial fishing activity than in the past, due to the cod moratorium, and local opinion suggests that this may have contributed to the recent increase in the local eider population.

Recently there has been interest expressed in having the Migratory Bird Sanctuary reestablished and that is one tool that is available to assist us in our conservation efforts. A Bird Sanctuary, however, requires the support of the resource users in order to be effective.

In partnership with the EHJV, the Town of Mary's Harbour, along with the Town of Red Bay and St. Lewis, through the signing of a coastal stewardship agreement have agreed to support the development and promotion of best stewardship practices for the coastal area of St. Peter's Bay. The residents of the community will be encouraged to become caring stewards of the area, particularly those areas that have been identified by residents, EHJV biologists and others as being critical habitat for waterfowl. Through this Agreement, Mary's Harbour joins an international network of communities working together to ensure the sustainability of North American waterfowl populations.

The Common Eider

The Common Eider (*Somateria mollissima*) is the largest duck in the Northern Hemisphere and there are two races found in Newfoundland and Labrador; a Northern and Southern race. The Northern race (*borealis*) breeds in Labrador, Ungava Bay and the Eastern Canadian arctic and winter off the North and East coasts of Newfoundland. The Southern race (*dresseri*) breeds from Hamilton Inlet, Labrador, as far South as Maine and winter along the south coasts of Newfoundland, Nova Scotia, New Brunswick, and the Eastern United States.



Figure 1 - Common Eider

Eiders nest almost entirely on offshore coastal islands due to the fact that nesting islands are most often free from land-based predators. This predator-free environment is important since eiders nest in partially concealed hollows among grasses and shrubs, making them quite vulnerable. Disturbance to nesting females may cause them to abandon their nest, leaving eggs or chicks as easy prey for predatory gulls and other wildlife.

On the Island of Newfoundland, Common eiders were once highly numerous, but by the 1970's, the island breeding population is believed to have been reduced to approximately 500 pairs (*dresseri* race). Many factors are believed to have contributed to the drastic decline, but they include increased predation by gulls, over-hunting, egg collecting, disturbance on nesting grounds, habitat degradation, and oil spills. Northern *borealis* race populations have not been as drastically affected but have also experienced declines. The good news is that populations have recovered significantly since that time. Canadian Wildlife Service average population estimates, based on flight surveys conducted between 1996-2005 indicate that there are now approximately 21,000 breeding pairs of the southern *dresseri* race and approximately 19,000 breeding pairs of the northern *borealis* race in Newfoundland and Labrador and that both populations are believed to be increasing. Future target population objectives have been developed and indicate a current deficit of approximately 27,000 breeding pairs of southern *dresseri* race and approximately 7,000 breeding pairs of northern *borealis* race. To add to the significance of the Newfoundland and Labrador habitat contributing to Common eider populations, there is an estimated 114,000 eiders, comprised of both races, that winter and feed off our coastlines and includes birds from several jurisdictions.

Despite the increase in breeding population size Common Eiders still face pressure from predators, climate change, over-hunting and recreational tourism activities. Thus conservation efforts are necessary to aid eiders in reaching historic breeding numbers and to ensure their protection in the future.

The Harlequin Duck (Eastern Population)

The Harlequin Duck (*Histrionicus histrionicus*) is a small subarctic sea duck divided into two separate populations in North America: the eastern population and the western population. The eastern populations are found congregating a wide geographic range along the coast of eastern North America. During breeding season Harlequins are distributed from northern New Brunswick north to Nunavut (particularly Labrador and Northern Quebec) and during the wintering season they are found along the sea coast from insular Newfoundland, south to Maryland, U.S.A. and along the southwest coast of Greenland.

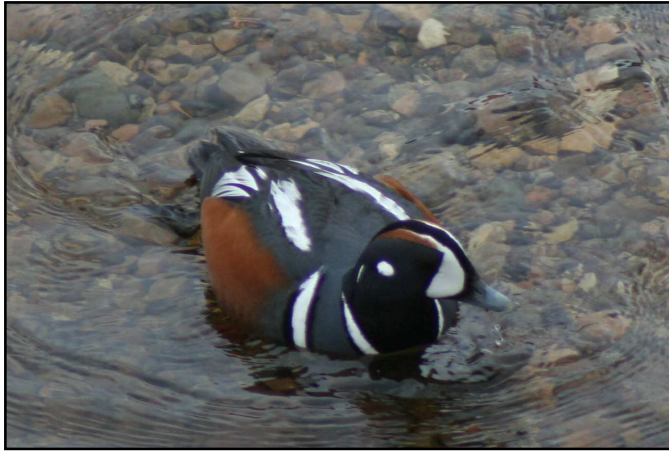

Figure 2 - Male Harlequin Duck, Photo by: Charmaine Barney

The harlequin's choice of habitat is also wide ranging. In the spring, their preferred habitat includes river mouths, inland rivers and streams, and estuaries where they can breed along fast flowing river systems and feed on abundant invertebrates. However, in northern Labrador a narrower, warmer and less acidic river is preferred. In the winter, harlequins prefer the habitat of rocky coastlines, sunken reefs, subtidal ledges, and exposed headlands. They are also regularly associated with offshore islands.

In Newfoundland and Labrador, Harlequin Ducks are present year-round and thus subject to risk threats occurring in breeding, molting and wintering areas. In the breeding locations resource extraction and exploitation (forestry, hydroelectric development, mining, etc.), insect control programs, low-level aircraft flying and increased human access are believed to pose threats to harlequin's breeding success. In wintering and moulting locations, fishing nets, aquaculture development, illegal/accidental harvesting, boating activities, chemical spills and chronic and catastrophic oiling are also potential threats. In addition harlequins are more vulnerable in that they congregate in large groups and have a high fidelity to their wintering sites, naturally low reproductive rates, and are generally quite tame. These diverse threats have combined to historically negatively affect their population viability and a significant decline was observed in the eastern population.

In 1990, the eastern population of the Harlequin Duck was nationally designated as an endangered species. Since that time hunting of this species has been banned and there have been increased efforts in research and monitoring. Fortunately, since 1995, there has been a gradual increase in their numbers and in 2001 they were upgraded from Endangered to Species of Special Concern under the federal Species at Risk Act, and considered Vulnerable in Newfoundland and Labrador under the Provincial Endangered Species Act.

The breeding population of Harlequin Duck in Labrador is considered stable to increasing with approximately 395 breeding pairs while insular Newfoundland is largely restricted

to a small population on the Great Northern Peninsula. Their wintering population however remains relatively low compared to other waterfowl species with less than an estimated 2000 individuals as a whole, 200 of these occurring in Newfoundland and Labrador. The number of wintering individuals generally continues to decline in the northern range.

Harlequin Duck in Mary's Harbour

Thirty significant waterways have been identified in the Southern Labrador Region, including the Mary's Harbour region. The coastline is barren, with bedrock outcrop and stunted shrubs. Despite the apparent abundance of potential habitat, dedicated surveys of over 600 km of potential habitat on 13 river sections revealed no Harlequin Ducks. As a result of public observations, approximately five breeding pairs are estimated within the river sections of this Region.

St. Peter's Bay however is the traditional molting area for Harlequin Ducks along the south Labrador coast from late June through August. In the summer of 2004, boat surveys by the Canadian Wildlife Service counted 66 Harlequin Ducks near the St. Peter's Bay Islands.

Several small coastal communities of greater densities occur in southern Labrador and are situated in the vicinity of estuaries and therefore staging areas of Harlequin Duck. The main risk to harlequin ducks near these coastal communities is hydrocarbon contamination during resupply or other spills associated with shipping.

As the coast of Labrador is usually frozen for at least several months annually, wintering by this species is not likely in Labrador and has not been documented.

Description of the Stewardship Zone

St. Peter's Bay and the islands which inhabit the area are very productive and support various waterfowl and sea ducks including the common eider which spend most of its life around the area. The lack of disturbance provides ideal eider habitat and with the signing of the Stewardship Agreement these areas will continue to be exceptional.

The Stewardship Zone in St. Peter's Bay was determined by the EHJV staff in agreement with the Town and residents of the area. The west boundary was determined by using the coastal land and the others were chosen by including most islands and habitat that eiders were using. The islands in the conservation area are very important sea duck habitat as well as the coastal cliffs and shoals. We hope to encourage residents of the area to adopt a sense of responsibility and ownership towards their natural surroundings and to the area inhabiting the St. Peter's Bay. (Appendix 2) (Appendix 3)

Existing Land Use and Its Potential Impact on Coastal Habitat and Sea Duck/wildlife populations

Residential Development

Much of the area currently designated as the Stewardship Zone within St. Peter's Bay would, generally, not be considered a priority area for development into residential housing or for other commercial interests. Development along coastal areas and in particular, areas known to support seabirds should be treated with caution to reduce the impact on these species and to limit the amount of habitat loss associated with this development.

Hunting

In part due to the lack of education and sufficient enforcement there is a significant history in Newfoundland and Labrador of extensive illegal over-hunting and the harvesting of Common eider eggs during the spring and early fall. However, in more recent years, both the federal and provincial governments have imposed stricter regulations and increased enforcement to help control over-harvest. Hunters, as individual conservationists and stewards can and do play a significant role in conserving migratory bird populations when they respect wildlife habitat and support legal harvest limits.

Fishing

Like many communities in Newfoundland and Labrador, a major source of income for families in Mary's Harbour comes from the fishing industry. Seabirds are typically long-lived, mature late in life, and exhibit low fecundity; thus, populations are vulnerable to mortality influenced by humans, such as occurs through incidental catch in fisheries.

Fishers should be aware that entanglement in fishing gear including pelagic and bottom-set longlines, pelagic driftnets and pelagic and bottom-set gillnets is a significant source of incidental mortality for many seabird species worldwide. Birds may also be captured as nets are set or hauled, or in an attempt to feed on entangled fish near fishing vessels, however fishers can actively work to reduce this risk, as well as preventing the risk of accidental oil or fuel spillage.

Timber harvesting

Timber harvesting in Southern Labrador, for the most part, have been occurring in areas away from coastal habitat. However, the possibility of it occurring near waterfowl habitat would negatively impact local waterfowl and seabird populations. The primary effect of timber harvesting close to water is the loss of nesting habitat in upland areas.

Oil Spills

Accidental oil spills can also disastrously impact seabird populations. Oil is one of the most common pollutants in our water and can cause numerous effects on birds that inhabit the shores and waters of Newfoundland and Labrador. Recent studies have shown that every year, more than 300,000 birds are killed by oil off the south coast of the island of Newfoundland alone.

Section 4: General Policies for Coastal Habitat and Sea Duck Conservation

The coastlines of Newfoundland and Labrador provide very important habitat for many species of plants and animals including sea ducks and seabirds. This diverse ecosystem provides food, shelter, places to raise young, and serves as a migration corridor for a variety of species including eiders, geese, gulls, scoters, cormorants, terns, puffins, loons, eagles, ospreys and many different shorebirds, songbirds and wading birds. Some of our coastlines provide areas in which these species can experience little disturbance throughout much of the year, specifically during the breeding season. However, human activity has had a substantial impact on the breeding success of some sea duck/sea bird species, namely the Common Eider. Knowledge of how our activities may negatively affect sea duck populations is the first step in addressing these impacts. The focus of the Coastal Habitat Stewardship Program is to encourage people to adopt a stewardship ethic, a responsibility, for these coastal areas while still allowing for the enjoyment of traditional outdoor activities.

The Town's Commitment to Stewardship

In signing a Coastal Habitat Stewardship Agreement, the Town has made a public commitment to join an international network of important coastal habitat areas contributing to sea duck/seabird presence and abundance in North America. Further, the Town has committed to using this conservation plan as a guide to best management practices in/around coastal habitat and sea ducks/seabirds within its Stewardship Zone. It is hoped that a stewardship ethic will be fostered within the community since the conservation of coastal habitat and sea ducks/seabirds depends not wholly on conservation plans or regulations, but on the conservation/stewardship ethic of residents and of visitors to the Town.

The Stewardship Zone will be managed to ensure the maintenance and possibly enhancement of coastal habitat and sea duck/seabird populations. Managing bodies will include participating Town Council(s), the Department of Environment and Conservation, Wildlife Division, through staff of the Eastern Habitat Joint Venture and individual residents.

Benefits for Residents

The strategies outlined in this Conservation Plan can provide many long term recreational and "quality-of-life" benefits for local residents. Coastal habitats are ideally suited to a variety of consumptive and non-consumptive recreational activities, including fishing, hiking, photography and bird-watching. The Town may wish to use these opportunities to increase tourism to the region. In developing recreational and tourism opportunities, careful consideration for the wildlife populations must be included in the planning

process. Otherwise, human activities may result in negative impacts to the very resource that is providing the attraction.

Surely, one of the most important benefits that people receive from stewardship is the opportunity to increase their knowledge of coastal habitat and nature in general. Many of the education, enhancement and restoration strategies outlined in this Plan can be easily conducted by local community interest groups, thereby allowing "hands on" involvement in conservation efforts.

Habitat Management of the Stewardship Zone

It is the intent of the Stewardship Agreement that habitat development activities occurring within the Stewardship Zone will be conducted on a "sustainable use" or "wise use" basis. As such, any development activities undertaken should not intentionally cause the loss of coastal habitat or sea duck/seabird populations. Consequently, coastal habitat and sea duck/seabird populations will be at the forefront of management decisions which may impact the Stewardship Zone. Development proposals which, in the view of town council(s) or its managing committee(s), may impact coastal habitat or sea ducks/seabirds within the Stewardship Zone should be forwarded to staff of the EHJV for comment with a thirty day notice period.

"Wise Use" of the Stewardship Zone

Determining what is wise use of wildlife habitat is not always easy however, there are several ways in which use can occur but still accomplish the goal of protecting sea duck/seabird populations. As it relates to the Common eider, the following outlines guidelines for town residents to, as best as possible, live in harmony with eider populations:

- 1) Generally, where possible, avoid sea duck nesting islands in the spring, but, especially eider islands during May and June.
- 2) If you must go to a nesting island, stay near the shore and out of sight of nesting females.
- 3) Never remove eggs from the nests.
- 4) Never chase or harass ducklings.
- 5) Always avoid young eider while operating motor boats since ducklings are very vulnerable if they get separated from the adults.

If you hunt eiders or other waterfowl you should remember to:

- 1) Always stay within prescribed bag limits.
- 2) Do not hunt out of season.
- 3) Know your ducks so that you do not mistake eiders for other species of waterfowl.

For those who would like to get actively involved in eider conservation the following list provides a list of ways you may help.

- 1) Help build, place and restore eider nest shelters.
- 2) Report observations of new or abandoned nesting, brood rearing, feeding, moulting or overwintering locations.
- 3) Report any obvious imminent dangers to the eider population (this could be wildlife predators, human activity, weather or other factors).
- 4) Consider options for permanently protecting private land inhabited by eider ducks.
- 5) Help minimize the effects of commercial activities on eiders.
- 6) Invite/welcome educational speakers to your community to speak on stewardship and conservation of eiders.
- 7) Spread awareness of the need to protect nesting grounds among pleasure boaters and fisherman.
- 8) Encourage others to get involved in eider conservation.

Management by Committee

It is recommended that Towns seek to manage their Stewardship Zone via a formal committee of council or a joint committee when several communities are involved with a coastal area. This may take the form of an “Environment Committee” or “Coastal Habitat Committee” generally chaired by a member of council with volunteers from the local community making up the remainder of its membership. It has been our experience that such, often dedicated and dynamic, committees often have greater success in raising the profile of the environment and the coastal habitat areas within the larger community thereby increasing public understanding and support over the long-term. By involving local individuals a greater sense of ownership is fostered thereby strengthening the conservation commitment.

Section 5: Coastal Habitat and Sea Duck Conservation and Education Strategies

Artificial Nest Shelters

One of the major focuses of the coastal habitat stewardship program is the Common Eider. Eider populations are limited by duckling survival. One of the major projects historically undertaken in many of the Newfoundland and Labrador communities where eiders are found is the placement of nest shelters (Figure 1) on breeding islands. In recent years this work has been championed by some local development agencies and specifically by Ducks Unlimited Canada, a partner of the EHJV, in what was known as the “NL Eider Initiative”. These artificial nest shelters are generally made of wood (Appendix 5) and are intended to protect young ducklings from predation by gulls/corvids and allow them time to grow prior to leaving the nest for the water. They have been shown to be significantly successful in improving the percentage of ducklings which fledge successfully. The placement of nest shelters on offshore islands should only be undertaken in consultation with staff of the EHJV.



Figure 3 - Eider Nest Shelter - Photo by EHJV Staff

Sea Duck/Seabird Monitoring Program

Staff of the EHJV have devised an easy to use community-based sea duck/seabird monitoring protocol (see Appendix 6) and will assist community partners in its implementation. It is hoped that Towns, local community interest groups and interested volunteers (often bird-watchers) will establish a monitoring program within the Stewardship Zone. The program could even be incorporated into portions of the regular school class curriculum or into the objectives of local natural heritage organizations. Data collection can provide information on changes that are occurring within the coastal

habitat and can indicate problems or progress towards a desired goal of sea duck/seabird populations. Monitoring can also provide data on whether a site is developing in a way that is conducive to achieving a community's goal. Regular monitoring can also be a way to flag potential problem areas (i.e. early indicators of water quality issues). Additionally by involving local residents, the profile of the area is enhanced to the long-term benefit of conservation.

Hunting

It is the clear intent of the Wildlife Division and the Eastern Habitat Joint Venture that hunting, as a sustainable consumptive resource use activity, be maintained within coastal habitats that contain sea ducks and seabirds. However, it is important to understand that the provincial Wildlife Act and associated Wildlife Regulations indicate that shooting is not permitted within 1000m of a school, playground or athletic field or areas that are within 300 m of a dwelling. If required, appropriate signage may be developed through consultation with Wildlife Division staff and would need to have the section of the NL Wildlife Act from which the regulation has been quoted - pertaining to the illegal discharge of a firearm - clearly identified (Appendix 7). Placement of no-shooting signs should be left up to the discretion of local Conservation Officers.

In 1949, when Newfoundland entered Confederation with Canada, it was not initially bound by the provisions of the federal *Migratory Birds Convention Act*. This combined with a lack of education and enforcement led to extensive illegal over-hunting and the harvesting of Common eider eggs during the spring and early fall. Since that time, both the federal and provincial governments have imposed stricter regulations and increased enforcement to help control illegal over-hunting. Hunters, as individual conservationists and stewardship can and do play a significant role in conserving migratory bird populations when they respect wildlife habitat and support legal harvest limits.

Recreational hunting of eider is permitted during a fall-winter hunting season in Newfoundland and southern Labrador because the eiders present on these coasts and in the Gulf of St. Lawrence during the winter are not local breeders: they belong to larger Arctic breeding populations. The opening of the recreational hunting seasons on the island of Newfoundland in all coastal zones for long-tailed ducks (oldsquaw), eiders and scoters is the fourth Saturday of November to the last day of February. Daily bag limits for these species are 6, and the possession limit is 12. It is mandatory for all hunters to use Non-toxic shots for all migratory bird hunting. Lead is a toxic substance previously used in hunting migratory game birds but was found to be toxic to wildlife and the environment. By setting an example of ethical hunting practices, each hunter helps to ensure a future for migratory bird hunting. Using a non-toxic shot will help conserve the health of bird populations and their habitats.

Oil Spills

When birds get coated with oil their feathers become matted. Oily, matted feathers cause the bird to lose their ability to fly and insulate themselves, and because of this, the birds can die from hypothermia. Also, when the bird tries to clean the oil off of its feathers, it may swallow oil and other toxins which can lead to many different internal problems. For example oil on the feathers of an incubating seabird may also be carried to its eggs, and if the oil soaks through the shell, it can kill the embryo or cause abnormalities in the developing chick. Even a small amount of oil—a spot no bigger than a quarter—may be enough to kill a seabird.

The major solution to this problem is the prevention of spills in the first place, particularly in relation to the use of these chemicals on fishing and recreational boats.

Recreational Use Development

Recreational walking and bird watching have become some of the most popular non-consumptive outdoor activities that occur across Canada. In many stewardship zones there may exist the potential to develop a trail system and/or interpretive signage to allow public access to your community's significant coastal habitats. This will help raise community awareness of the habitat and the stewardship agreement. Trail or other development should be undertaken in consultation with staff of the EHJV. One of the most effective ways for people to learn is through doing. Bringing young people and members of the general public into special areas (in a natural setting) for the purposes of applied learning would be a critical part of any educational programming planned for the area.

Sustainable, recreational, use of coastal habitat can be encouraged with the designation of a walking trail whereby foot traffic can be controlled and access to the any fishing, canoeing, or nature-viewing can still be facilitated. Care must be taken during any trail construction so as not to degrade the quality of habitat. Trail maintenance will be required and this responsibility should also be clearly understood from the outset. Potential signage, other than interpretation, might include critical times for sea duck/seabird nesting and brood-rearing, and could be posted at areas along a walking trail and at a potential parking area to raise awareness of the sensitive nature of the area and to identify the best times to utilize the area to minimize disturbance. Critical times for sea duck/seabird nesting and breeding could also be posted discreetly at points around the Stewardship Zone.

Several stewardship communities have taken the concept of recreational use of their stewardship areas a step further, actually building "Interpretation Centres" in strategic locations targeted to bring residents and visitors into the conservation area to enjoy and learn about the coastal habitat and wildlife. These buildings, shelters or amphitheatres can serve as wonderful, natural locations for certain educational programs and seasonal

community activities where a more permanent venue is appropriate. This type of project would lend itself to specific sources of funding or grants (i.e. Commercial Building Incentive Program). Other venues of this sort have been funded and assisted in core-funding by industry leaders like Petro Canada (Fluvarium) and Irving Oil (the Irving Eco-Centre). A leading petrochemical company (Conoco-Phillips) has indicated that a portion of its environmental mandate for the Burin Peninsula may include fostering stewardship through education. Given the history of Conoco-Phillips involvement with preserving and protecting habitat for birds all over the world, this industry giant has the potential to play an important role in the development of a stewardship centre or any other stewardship related project.

Conservation Corps Green Teams

The Newfoundland and Labrador Conservation Corps annually sponsors summer “Green Teams” and “Interns” generally comprised of university and high school students, to work within communities on worthwhile environmental projects. In the past, such teams have been placed in communities with Stewardship Agreements. Projects may include such things as constructing and installing eider nest shelters and nesting platforms (for geese) followed by subsequent monitoring throughout sea duck/seabird breeding/brood-rearing seasons. Green Team members could be tasked with training local high school students or community members in appropriate monitoring protocol and could develop brochures and educational material designed to raise awareness for conservation and stewardship initiatives. This project could be extended to bird houses and would serve to provide data on birds using various habitats within the entire Coastal Habitat Stewardship Zone.

Artificial Nesting and Loafing Structures

A) Osprey nests

Ospreys are fish eating raptors that are frequently observed hunting in wetland habitats, particularly those along the coast. Unfortunately, populations of these birds plummeted in North America during the 1950's and 1960's due to the wide spread use of pesticides and other pollutants which have a tendency to bioaccumulate in birds of prey, like the osprey. For many osprey populations, bioaccumulation results in frequent reproductive failures. With the banning of many pesticides in the early 1970's, many osprey populations have made a comeback.

Osprey prefer to nest on tall, often dead, trees on the shoreline of lakes and bays that are at least 2 metres deep but make nests in a multitude of locations (i.e. telephone poles, communication towers, etc.) as long as the area is wide open with an adequate food supply (Figure 2). Preferred natural sites are scarce due to timber harvesting and shoreline developments.



Figure 4 – Osprey Nesting Platform, Stephenville Crossing.
Photo by: Charmaine Barney

In many parts of Canada, the installation of artificial nest structures by concerned citizens and community groups have facilitated the comeback of the osprey. Osprey nest structures have been installed at several sites in Newfoundland, including the Memorial University Botanical Gardens in St. John's, the Stephenville Crossing area and in Winterland (see Appendix 8). Many people take great pleasure in watching these majestic birds raise their family and fish the shallow waters of nearby lakes and bays.

It may be advisable to install a single osprey platform at a carefully chosen location to determine whether the ecosystem can sustain a single, monogamous, breeding pair of osprey, with subsequent platforms planned accordingly. In conjunction with an observation tower, area residents could potentially enjoy a "bird's eye view" of osprey daily life high atop an artificial nesting structure. Artificial nesting platforms should be located in areas with minimal human use and where human impact would be least.

Involvement of schools, youth groups and community organizations in the construction/maintenance/observation of the nesting structure could instill a sense of pride and awareness that would go far in fostering a community stewardship ethic.

B) Island Construction

A number of wildlife species, such as terns and waterfowl, nest and loaf on islands due to a reduced risk of predation from land-based predators. Many of the wildlife species present within wetlands would benefit from the construction of artificial islands. These structures can be constructed simply from wooden cribs (Tamarack Larch would be an appropriate choice for building material), measuring approximately four square meters that have been filled with rock and soil (see Appendix 9). The islands must be positioned so that they are higher than the highest water mark. Hardy shrubs and herbaceous plants (i.e. alder, willow) must be planted on the islands to provide cover and to prevent occupancy from gulls. Care must be taken to prevent the use of toxic construction materials (i.e. treated wood, contaminated soils) and disturbance to plant and animal communities. One must also consider the potential for increased predation on certain avian species that may use the constructed islands. One must consider the potential necessity for annual removal and reinstallation of islands in response to ice conditions tidal influenced areas.

Other forms of artificial islands exist and involve the planting of native marine plant species into landscaping fabric, which is then fixed to floating structures made of plastic piping or empty gabion baskets. This type of floating island requires careful placement in areas that do not have widely fluctuating salinity levels and require placement such that disturbance would be minimal during the period in which roots are establishing. Floating islands may be beneficial in terms of oxygenating the water column, as algal blooms would not “smother” the highly perched plants. The floating plants should, ideally, continue photosynthesizing despite the presence of algae, and may be of benefit in “taking up” some of the excess nutrients in the estuary effectively deterring algae growth. These floating islands would also, likely, require annual removal and reinstallation.

Educational Programs

Public education is essential in the development of a greater sense of coastal habitat stewardship among community residents. There are several well developed educational programs which can be tailored specifically to coastal habitat and sea ducks/seabirds which can be used to help foster this support.

A) Project Wild

Project Wild is an educational program implemented by the Newfoundland and Labrador Wildlife Division and is aimed at youth from kindergarten to grade six. Its goal is to develop awareness, knowledge, skills and commitment resulting in informed decisions, responsible behavior and constructive actions concerning wildlife and the environment upon which all life depends. Project Wild is not just “wildlife” education. It is a broad environmental education program focusing on wildlife. Wildlife is used as a tool that naturally captures student interest and as a symbol for the fragility of the environment providing a means to also educate youth about the value of wetlands for waterfowl.

B) Greenwing Program

This conservation awareness program targets grade four students, who have been identified as being most ready to receive and consider conservation messages. The Greenwing program is initiated by the “adoption” of a fourth grade class by local businesses or individuals. Members are then given a wealth of items ranging from t-shirts and lunch bags, encouraging a conservation-minded approach to daily life, and educational magazines revealing the wonders of wetlands, wildlife species and natural areas.

Greenwing events are also available to any Greenwing members, where conservation minded adults (i.e. potentially EHJV staff members) host project days or educational field trips with support from Ducks Unlimited Canada. Greenwing members who attend a Greenwing event typically leave an event with a greater sense of conservation awareness, and a parting item like a birdhouse or birdfeeder.



Habitat Enhancement

In some coastal areas, the surrounding habitat, specifically banks and sand dunes may have already been degraded or lost. The planting of bank or shoreline stabilizing plants is a viable project in localized areas and is a possible activity for summer Green Teams. In terms of their bank or shoreline stabilizing properties Blue-joint Grass and Dune Grass (*Ammophila breviligulata*) may be the appropriate choices. Once established these grasses would also provide a great deal of cover and concealment to waterfowl species. Low growing native shrubs may be interspersed with either grass species to enhance the desired effect of seclusion. These habitat enhancement activities should only be undertaken in consultation with staff of the EHJV.

Litter Removal

It is strongly recommended that community interest groups and individual residents work cooperatively to remove the large quantity of litter in and around all or portions of the Stewardship Zone on a regular basis, while making certain to avoid those times of year (May to July) when sea ducks/seabirds may be disturbed during breeding or brood rearing periods. Programs such as Ocean Net and Vanaqua Shoreline Cleanup (Figure 3) assist communities in organizing litter cleanups and they also provide supplies.



Figure 5 - A Newfoundland Beach Cleanup, Vanaqua Shoreline Cleanup

APPENDICES

APPENDIX 1

COASTAL STEWARDSHIP AGREEMENT

THIS AGREEMENT made at Mary's Harbour, in the Province of Newfoundland and Labrador this 9th day of November, 2009.

BETWEEN: **HER MAJESTY THE QUEEN IN RIGHT
OF NEWFOUNDLAND AND LABRADOR,**
as represented by the Honorable the Minister
of Environment and Conservation

(hereinafter called the "Minister")

-of the one part-

AND: **THE TOWN COUNCIL OF MARY'S HARBOUR**
a corporation pursuant to Section 15 of the *Municipalities Act, 1999*

(hereinafter called the "Town")

-of the other part-

WHEREAS the Government of Newfoundland and Labrador has entered into an Agreement with various partners for the implementation of the North American Waterfowl Management Plan through the Eastern Habitat Joint Venture;

AND WHEREAS the parties hereto recognize that stewardship of coastal ecosystems is fundamental towards maintaining and enhancing the sea duck and seabird populations in the province;

AND WHEREAS the Minister proposes that certain coastal ecosystems be protected and enhanced through stewardship and education activities with the cooperation of the Partners and resource users in accordance with this Agreement and the Conservation Plan developed hereafter;

AND WHEREAS the Partners have agreed to enter into the Agreement for the purpose of protecting and enhancing those coastal ecosystems.

NOW THEREFORE IT IS AGREED BY THE PARTIES HERETO AS FOLLOWS:

1. The conservation of the coastal ecosystem herein delineated and designated as a Stewardship Zone (being those areas outlined on a certain Schedule annexed hereto and marked "A") shall be supported by a stewardship program delivered in accordance with the terms and conditions of this Agreement and of the Conservation Plan developed hereunder for better protection of this coastal ecosystem for sea ducks, sea birds and other associated wildlife.
2. The parties hereto agree to cooperate in the promotion of best stewardship practices that will be identified in the Conservation Plan to positively influence activity within the Stewardship Zone.
3. The Conservation Plan shall be developed in cooperation with the Minister and the Minister agrees to provide such advice and expertise necessary or advisable for the development of the Plan.
4. The parties to this Agreement, their consultants, servants, or agents, shall have and exercise reasonable rights of access to the Stewardship Zone for all purposes necessary or incidental to this Agreement and in particular, but without limiting the generality of the foregoing, for the purpose of developing and carrying out the Conservation Plan.
5. Each of the parties agree that they will exercise their best efforts to further develop conservation measures for more effectively carrying out of their mutual intentions as expressed in this Agreement.
6. The parties recognize that this Agreement is not legally binding, but is a goodwill commitment between partners.

IN WITNESS WHEREOF the parties have caused these presents to be executed in accordance with their respective rules and regulations the day and year first before written.

SIGNED SEALED AND DELIVERED

by the Honourable the Minister of
Environment and Conservation in the presence of:

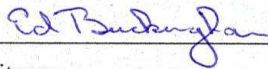

Witness

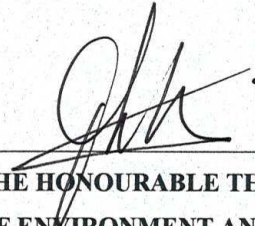

**THE HONOURABLE THE MINISTER
OF ENVIRONMENT AND
CONSERVATION**

THE SEAL OF the Town Council of
the Town of Mary's Harbour hereunto
affixed in the presence of:

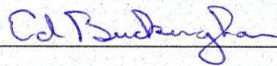

Witness



**THE TOWN COUNCIL OF THE TOWN
OF MARY'S HARBOUR**



SCHEDULE A

APPENDIX 2 (Schedule A)

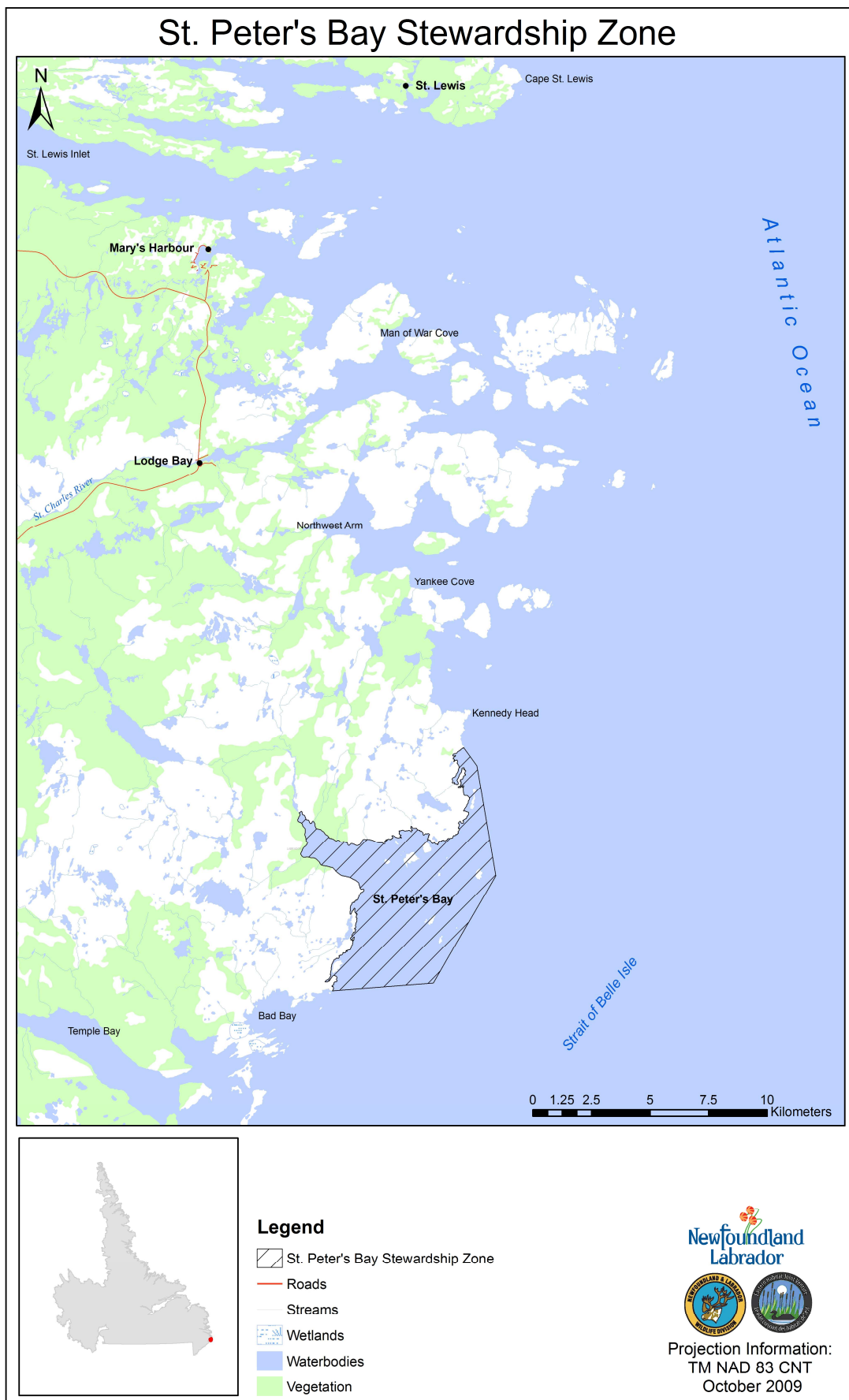

APPENDIX 3

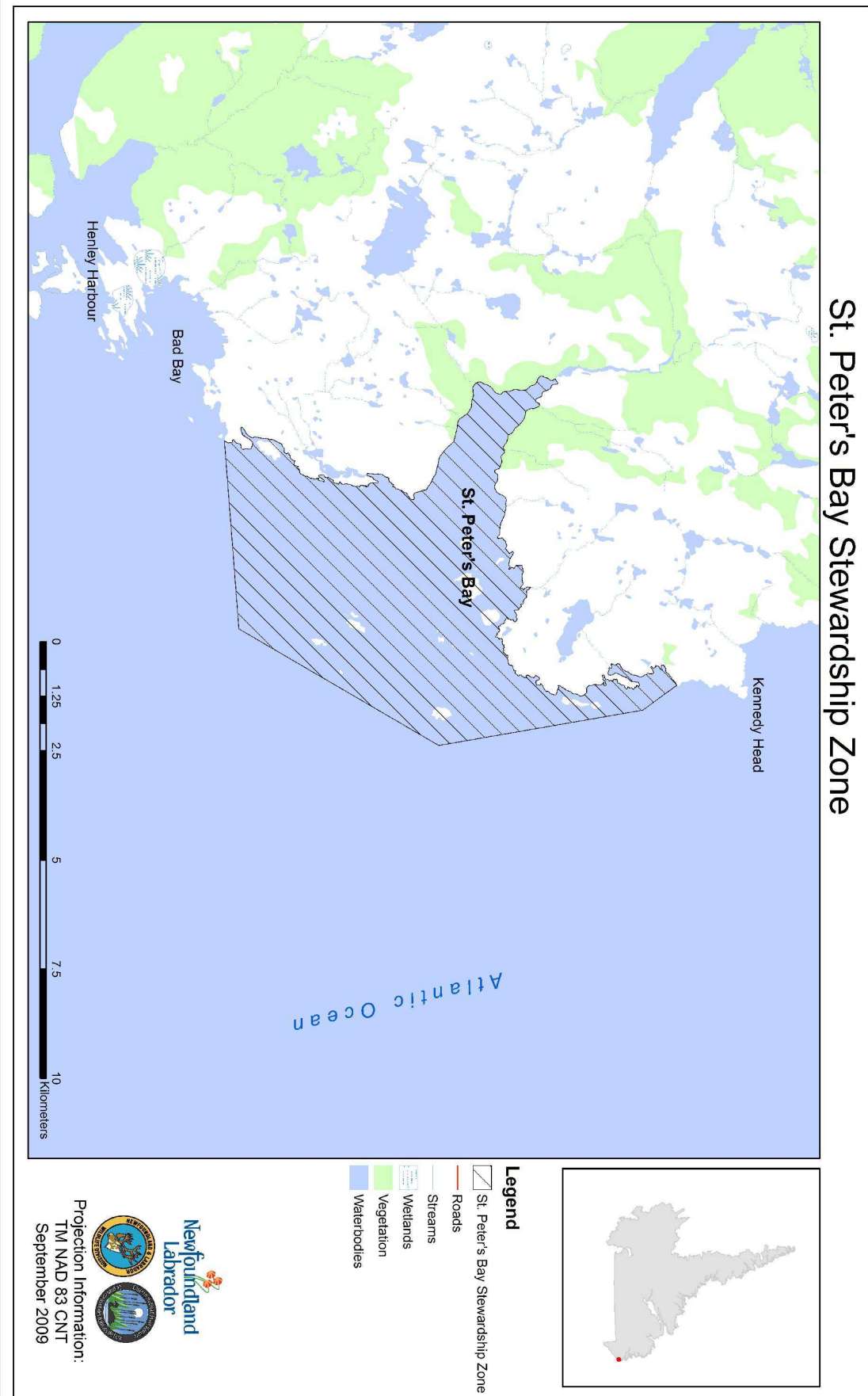

APPENDIX 4
Some Avian Species found in St. Peter's Bay

Group	Common Name	Scientific Name
Waterfowl	American Black Duck	<i>Anas rubripes</i>
	Canada Goose	<i>Branta canadensis</i>
	Harlequin Duck	<i>Histrionicus histrionicus</i>
	White-winged Scoter	<i>Melanitta fusca</i>
	Surf Scoter	<i>Melanitta perspicillata</i>
	Common Merganser	<i>Mergus merganser</i>
	Red-breasted Merganser	<i>Mergus serrator</i>
	Common Eider	<i>Somateria mollissima</i>
Seabird	Herring Gull	<i>Larus argentatus</i>
	Ring-Billed Gull	<i>Larus delawarensis</i>
	Greater Black-Backed Gull	<i>Larus marinus</i>
	Common Tern	<i>Sterna hirundo</i>
Alcid	Black Guillemot	<i>Cepphus grylle</i>
	Atlantic Puffin	<i>Fratercula arctica</i>
Other	Common Crow	<i>Corvus brachyrhynchos</i>
	Common Loon	<i>Gavia immer</i>
Hawk	Osprey	<i>Pandion haliaetus</i>
Mammals	Harbour Seal	<i>Phoca vitulina concolor</i>

APPENDIX 5

Instructions/Materials for Construction of Common Eider Nest Shelters

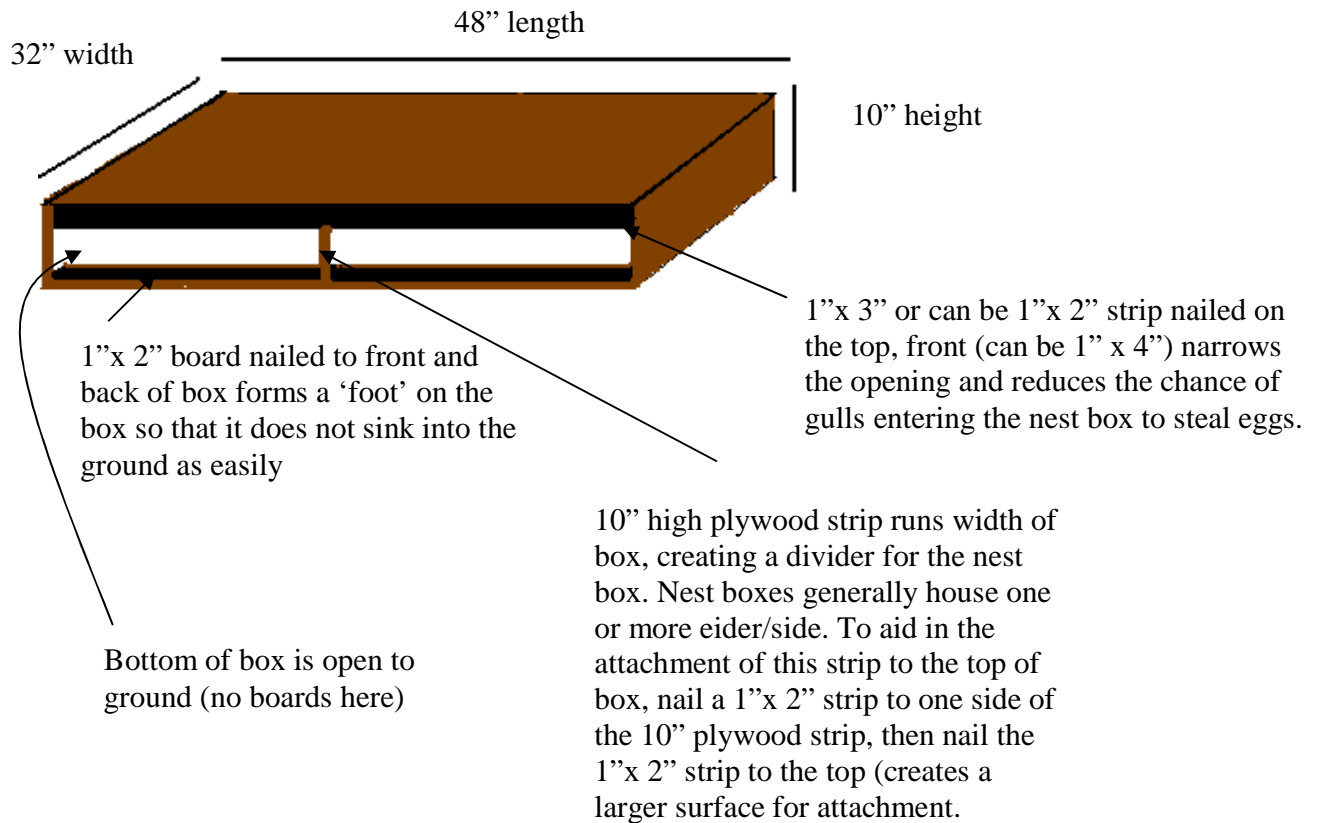

*Top, sides, and middle divider are made of plywood.
Plywood = 1/2" standard or D grade.

Approximate amount of materials to construct one double box:

Quantity	Material
1	sheet plywood
2	1"x 4' x 8'
0.12	can of water base stain
0.5	lb galvanized nails



APPENDIX 6

Community – Based Waterfowl Monitoring Project Protocols and Data Sheets

Generally within a community's wetland Management Units, a set number of locations for viewing waterfowl are chosen and outlined on a detailed map. These sites are chosen, for ease of access and ability to view waterfowl over a wide area, but they are also relatively evenly distributed around the wetland. Sites can be chosen to sample productive, historically productive and potentially non-productive waterfowl locations to give a representative snapshot of inhabitants of the estuary.

Each site location should be visited during a single day, within a two-three hour period, which will mean, in most towns, that more than one person will need to be involved. The survey should occur, at least once within a two week period in both the spring and fall. You are most welcome to complete and record as many observations as your schedules permit but the above indicates that, at a minimum, at least two surveys would occur annually.

These surveys should occur **during the last two weeks of June and during the first two weeks of October and should occur either in the early morning (starting at dawn and up to ~ 3 hours afterwards) or in the early evening (starting ~3 hours before dusk).**

If you are not already familiar with the area it would be advantageous for you to become familiar with the sample locations identified on the map prior to the day of your survey. It may also be prudent to seek private landowner permission in advance of your intended survey day. In addition, identify access points (ex. determine whether best approached by foot or by boat) well in advance so that your survey can be completed in a single morning or evening.

Survey Locations

The intended survey sites should be relatively easy to access (off roads or meadows) and are intended to follow the shoreline of the wetland. **Observations should be made within a semi-circle** oriented towards the wetland instead of attempting to watch in a full circle all around you which could form an unnecessarily difficult amount of survey area in a short period. Orient yourself so that you can maximize the amount of wetland being observed (i.e. your view should not encompass a large swath of open field or roadway) **out to a distance of ~100m on either side of you.** It may be prudent to become familiar with what a 100m distance roughly looks like before setting up your survey.

Some sites may be more easily accessed by non-motorized water craft such as canoe or kayak. If you choose to use canoe or kayak, the centre of the semicircle will become your boat and you will orient your semicircle accordingly. It will be especially important to approach your survey site slowly and quietly by boat or kayak since your odds of flushing waterfowl will be increased.

Consider the following drawing as your sample area:

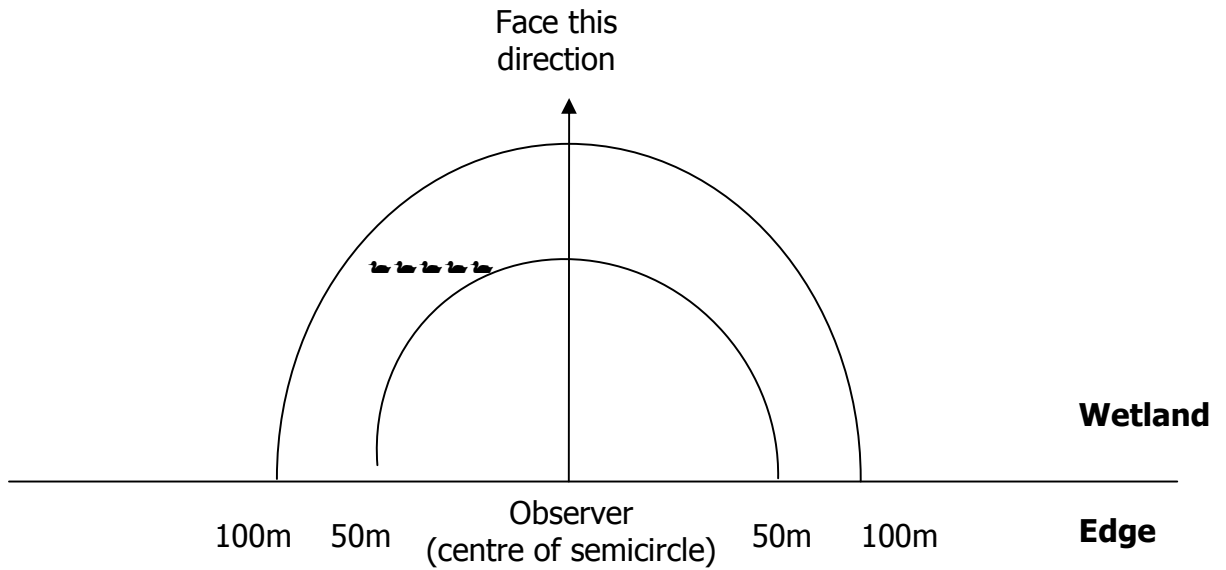

Tools you should consider having include the following:

- A keen eye!
- Field notebook or data sheet (attached)
- Pencil - record findings
- Watch - keep track of time (10 minutes per survey site)
- Bird field guide
- Pair of binoculars and/or a spotting scope (binoculars may be sufficient)
- Appropriate outdoor clothing
- Cellular phone in case of an emergency

Conducting the Survey

Surveys should only be conducted under suitable or good weather conditions.

This includes good visibility out to 100m, reasonably warm air temperature, little or no precipitation and little or no wind. If poor conditions develop and last for an extended period, it is suggested that you reschedule your survey for another day. **Once you have reached the survey site and oriented yourself so that you have maximal view of the area, sit quietly and begin timing for 10 minutes.** It is advised that you record any waterfowl that may be flushed out of the sample area during your approach and/or set up period in the space provided at the bottom of your record sheet, indicating that waterfowl left the area just prior to the survey.

Record all waterfowl species seen within the survey area during the 10minute period. If possible distinguish between male and female adults where possible and the numbers seen (including individual ducklings making up broods) in the appropriate space on the attached record sheet. Use a separate column for each sample site, identifying the site # at the top of the column. Also note any ducks that fly over, through, or out of, your sample area at the bottom of the reporting sheet.

Do not guess! It is entirely acceptable to record a species as unknown. You should be certain of the identity of a species before recording it. Birding workshops and informal bird watching excursions in your local area will make you proficient at identifying species common to your area in no time! If you find that you are recording several unknowns....that is perfectly acceptable. As years go by, you will become more and more adept at identification.

Additional Information to Record

If you are able to identify other, non-waterfowl, species of birds either by call or site in the vicinity of your survey area, please enter those in the space provided at the bottom of the appropriate column on the reporting sheets.

Excessive disturbance or noise from a number of sources (people talking, vehicles, farm equipment, boat traffic, etc.) could influence the behavior and movement of waterfowl that you are monitoring. Please take time to record any type of disturbance at the bottom of your reporting sheet (under the appropriate column corresponding to your survey site).

General / Safety Considerations

It is important to be mindful of the tides and the wetland (damp, soft, slippery) habitat that you may be asked to survey near, making personal safety your top priority. Further, if survey locations fall on private property, first seek permission from the land owner to access the property.

It is important throughout your survey that you aim to cause as little disturbance as possible to the birds that you are viewing, considering that many ducks will either be raising broods at the time of your survey or preparing for long migrations and a high level

of disturbance could mean an impact on waterfowl foraging. If you approach an area and it seems to be causing a hen to separate from her ducklings, leave the area. If you approach an area and an adult seems at all aggressive (i.e. Canada goose hissing), leave the area. Common sense is important; don't put yourself or the birds that you are watching in jeopardy.

Finally, **have fun!** The intent behind this survey is to have an enjoyable community waterfowl-monitoring effort. **Not every person has to commit to monitoring all of the same survey locations every year**, but your birding group may find it more manageable to have the same person (or group) monitor the same few sample locations year after year. If certain people in your community live close to certain survey sites, have special knowledge of certain sample sites or have a strong desire to sample certain sites year after year.....feel free to organize your survey group accordingly. Similarly, if you would like to rotate the groups of sites making up your larger survey area amongst your birding group that is acceptable, as long as the non-productive sites are factored into how you distribute the sites amongst volunteers.

What Will Happen to The Data?

Each year data sheets will be returned to EHJV staff who will compile the information to maintain a database on the diversity and abundance of waterfowl usage of the wetlands in question. This information is available on request but summary results will be forwarded to participants each year to keep you up to date on how your wetland and waterfowl are doing.

Feedback

We would appreciate learning more about any problems that you might have encountered with this protocol and would welcome any suggestions for improvement. The Eastern Habitat Joint Venture can be contacted anytime using the contact information enclosed.

The Completed Survey Sheets Should Be Returned To:

NL Eastern Habitat Joint Venture
Wildlife Division - Department of Environment and Conservation
P.O. Box 2007 • 117 Riverside Drive
Corner Brook, NL • A2H 7S1
Phone: (709) 637-2006
Fax: (709) 637-2032

APPENDIX 7
Appropriate Wording Required for Potential “No Shooting” Signs



**THE DISCHARGE OF A FIREARM
WITHIN 1,000 METRES OF A SCHOOL,
PLAYGROUND OR ATHLETIC FIELD,
OR WITHIN 300 METRES OF A DWELLING
IS NOT PERMITTED.**

**NEWFOUNDLAND AND LABRADOR WILD LIFE ACT
WILD LIFE REGULATION 111 (1)**

APPENDIX 8 Potential Artificial Osprey Nesting Platform

Instructions/Material for Artificial Osprey Platform Construction

Quite a number of osprey artificial nest designs have been developed for different habitats and sites. One of the more suitable designs for Winterland is the Minnesota Design. This structure is mounted on a single pole (i.e. untreated telephone pole) at least five meters above the ground. All nail and bolt holes are pre-drilled to prevent splitting. The wire mesh is nailed in the platform. Steel braces are bolted to the platform and the lag screws are used to secure the platform to the pole. Some sticks should be wired to the nest to help stimulate nest building. The use of tamarack larch or cedar is highly recommended.

Nesting structures should be placed within fifty (50) meters of water and at least one hundred meters from the nearest residence. Regular inspection of the structure is necessary. After a few years some nests become quite large because the osprey continually adds new sticks. This weight may cause support structures to break. If the nest does become large, it is often a good idea to remove some nest material outside of the breeding season. With proper construction and maintenance, the nest structure may last up to fifteen to twenty years. It is not uncommon for several years to go by without osprey use of the artificial structure. Only an osprey can ever truly know what an osprey seeks during placement of nesting structures!

Osprey Platform (Images Courtesy of the Minnesota Raptor Centre):

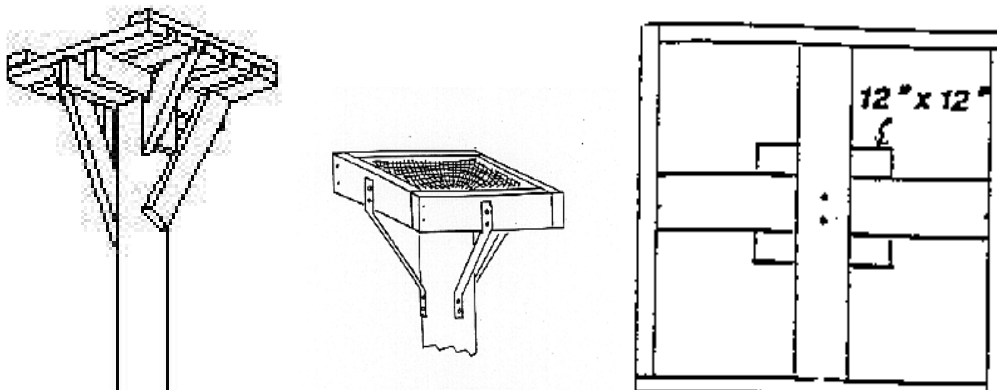

1) Platform View

2) Platform side-view

3) Osprey platform top view

Artificial Osprey Platform Design

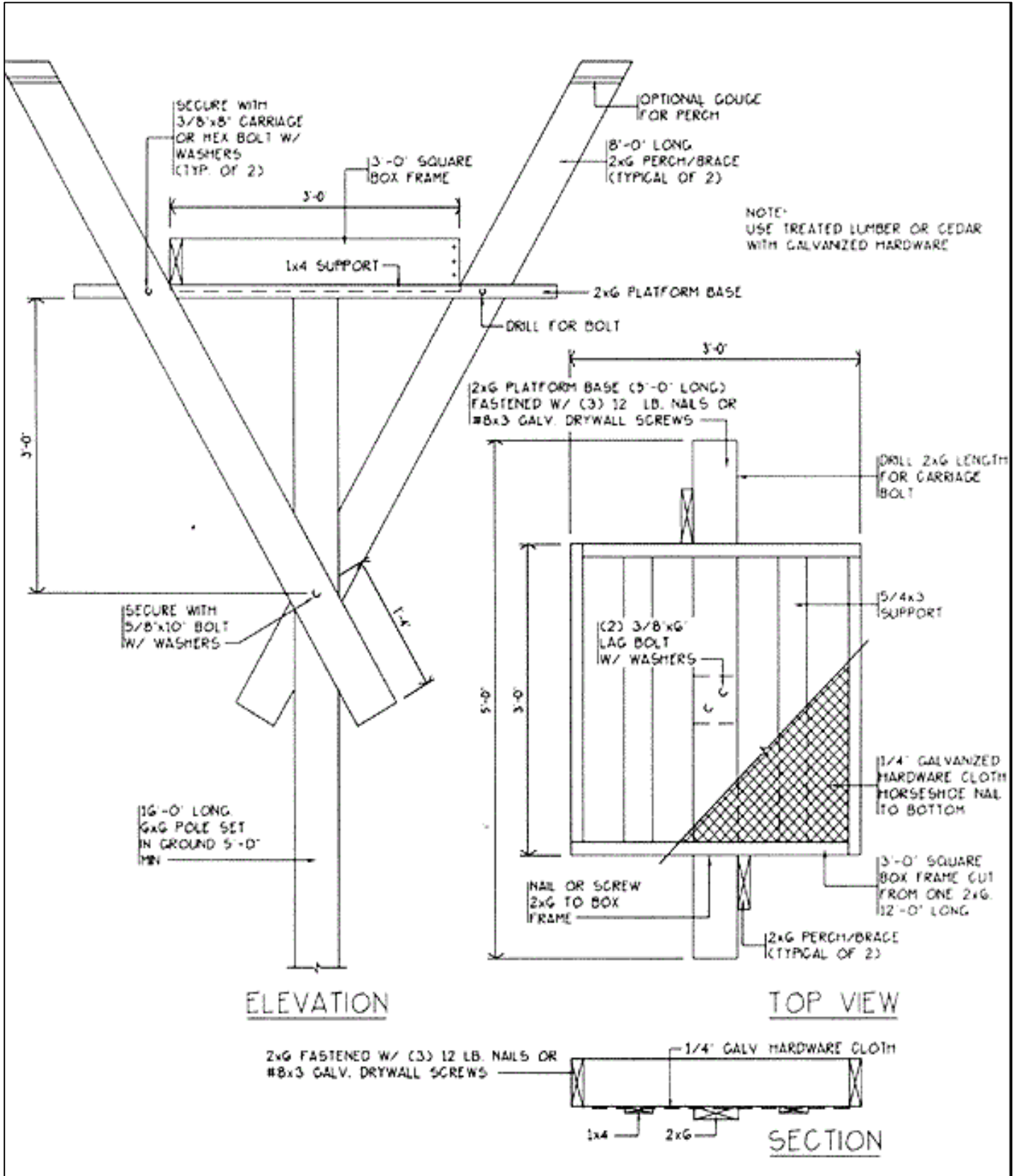

APPENDIX 9

Potential Constructed and Floating Islands

Instructions/Material for Constructed and Floating Islands:

- 1) 2m X 2m floating island constructed from high modular polypropylene floating booms and heavy gauge mesh:



Photo Courtesy of "Water Lines"

- 2) 3.5m octagonal floating island constructed from high modular polypropylene floating booms and heavy gauge mesh:



Photo Courtesy of "Water Lines"

- 3) By adding a floating island to a pond you will see dramatic improvements in the ponds water quality as well as the habitat for waterfowl. Islands are ideal for ponds surrounding towns to help improve wetlands as well as the habitat for waterfowl and other wildlife species. Visit CanadianPond.ca for more details.



Photos Courtesy of “Canadian Pond Products Limited”

4) Installation of floating island in the United Kingdom By “Water Lines” Staff:



Photo courtesy of "Water Lines"

5) Image of a timber rock crib installed in Kingsford, Mississippi by the Pine Creek Watershed Conservation Project. A proper crib is built from new, square-cut timber, not wire or driftwood or round logs tacked together with small nails. The timbers are assembled into a slatted, box-like affair. The box is then filled with rock and can weigh up to several tones:



Photo Courtesy of "Pine Creek Watershed"

- 6) Timber rock crib being installed in Kingsford, Mississippi by the Pine Creek Watershed Conservation Project. High quality construction would be essential to placement of this style of rock crib within the Shearstown Estuary to withstand ice and winter storm conditions. Design may have to be modified to deal with specific conditions existing within the estuary:



Photo Courtesy of "Pine Creek Watershed"

APPENDIX 10 Bird-watching (Viewing) Towers

Bird-watching (Viewing) Towers

View of bird-watching (viewing) tower overlooking estuary in Carleton, Quebec:



Picture Courtesy of Tourism Carleton

**View of bird-watching (viewing) tower overlooking estuary in Carleton, Quebec.
Built in 1990 for \$50,000 by local construction company (Tourism Carleton, 2005):**

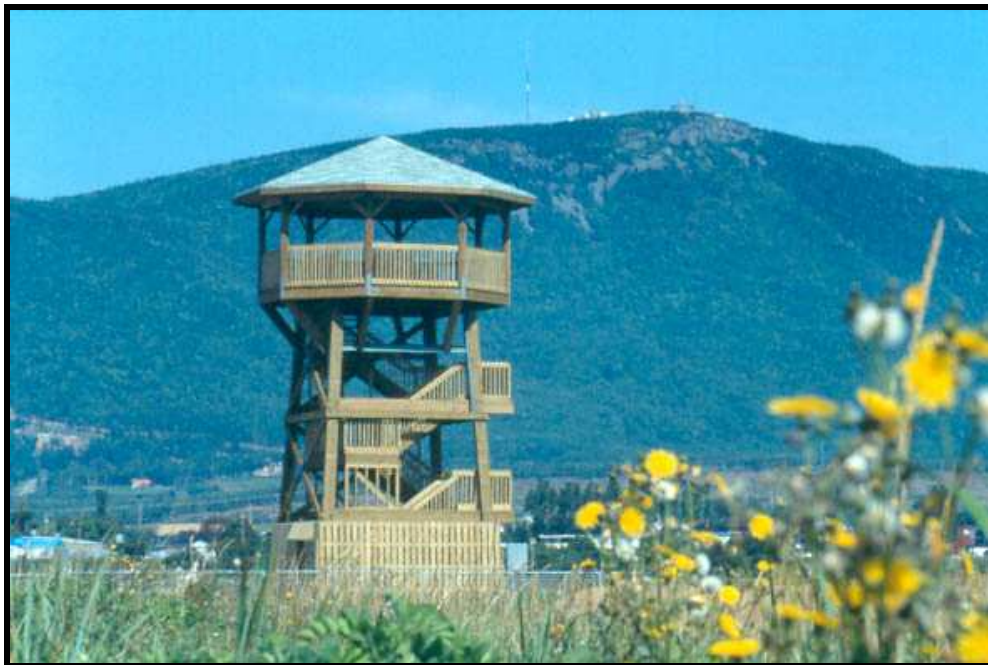

Picture courtesy of Tourism Carleton

APPENDIX 11 Construction of Bird Blinds

Image of inside and outside of bird blind in Grand Falls-Windsor:

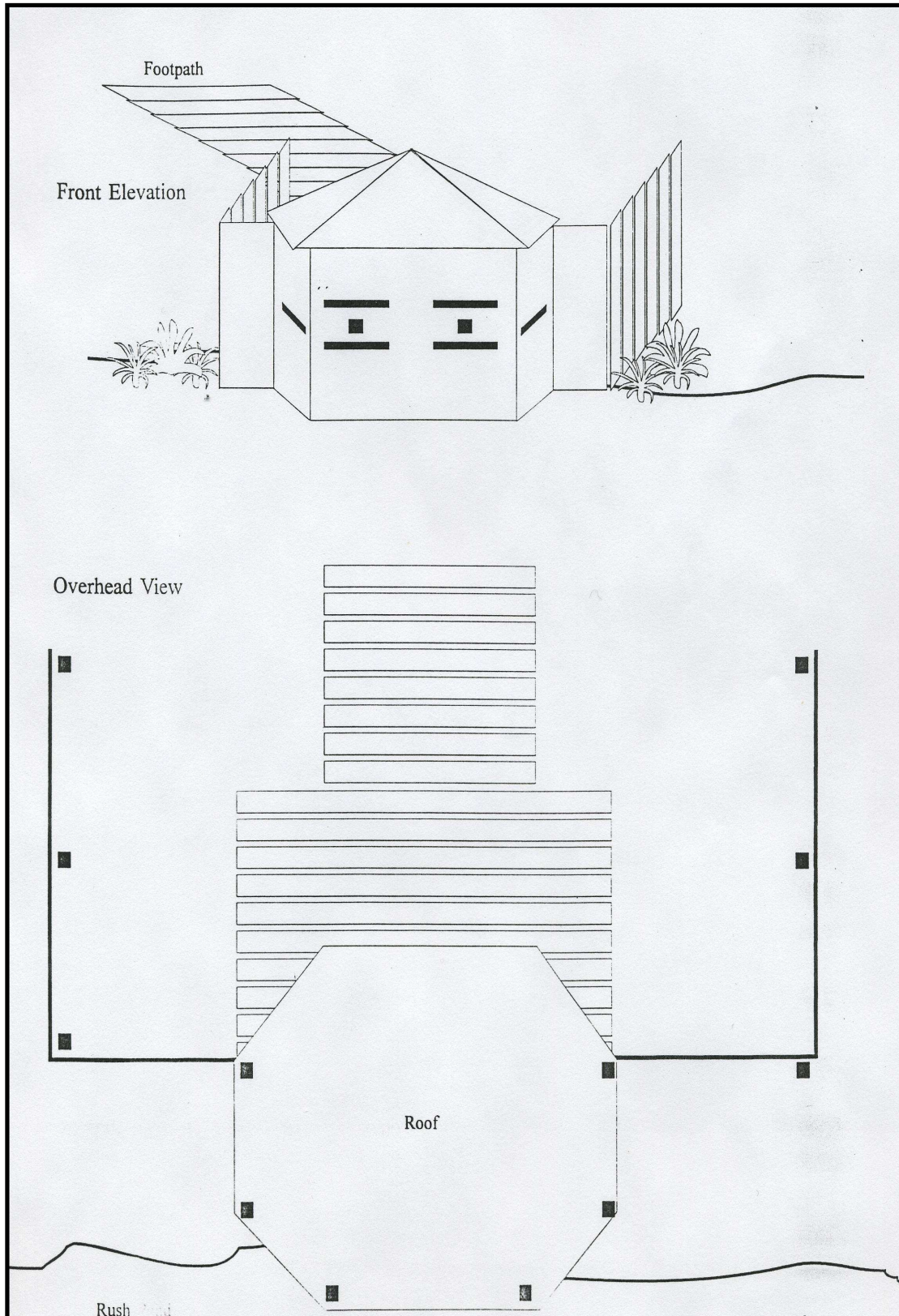

Photo Courtesy of Corduroy Brook Trail Association



Photo Courtesy of Corduroy Brook Trail Association

Design of a bird observation platform (“bird blind”):



APPENDIX 12 Observation Platforms



Photo by: EHJV Staff



Photo Courtesy of EHJV